



Altrad Australia: COMPLIANCE PROGRAM INTRODUCTION



Contents



CEO Message 1

Foundational Values 2

- Altrad's Core Values
- Altrad's Business Integrity & Ethics Code

Core Compliance Policies 4

- Anti-Bribery & Corruption
- Gifts & Hospitality
- Sponsorship & Donations
- Business Partners
- Conflicts of Interest
- Data Protection

Compliance Program 8

- Compliance Program
- ISO 37001 Certification
- Organisational Structure
- Controlled Documents
- Communication & Training
- Improvement & Monitoring
- Misconduct Consequences
- Compliance Platform
- Compliance Resources
- Whistleblowing

Since its establishment in 1985, Altrad has built a global reputation as a values-driven industrial services business, delivering expert construction and integrated asset maintenance solutions. We enable our clients and partners to achieve operational excellence through highly skilled people, adaptable solutions, and an uncompromising commitment to safety and sustainability.

At Altrad, compliance is not optional. Integrity and ethical conduct are fundamental to our success and to the trust placed in us by our clients, partners, and communities. Every Altrad activity must be conducted transparently, ethically, and in full compliance with the laws and regulations of the countries in which we operate.

Our core values demand the highest standards of behaviour. We maintain a strict zero-tolerance approach to bribery and corruption and expect the same from all employees, leaders, and business partners. These standards are non-negotiable.

Our Compliance Program exists to support this commitment. It provides the framework, guidance, and controls that enable sound decision-making in our daily work. It protects our people, safeguards our reputation, and ensures we operate responsibly and sustainably across all jurisdictions.

We are committed to being a clean organisation – one that leads with integrity, acts transparently, safeguards people and the environment, and always upholds the highest ethical standards. By embedding compliance and ethics into everything we do, we strengthen our culture, protect our licence to operate, and reinforce Altrad's position as a trusted global leader.

As CEO, I am personally accountable for upholding these standards and expect every leader across our business to demonstrate the same commitment.

**CEO, Australia
Brendan Chaplyn**

**Trust is our foundation, integrity
our path—protecting our clients
and securing the future we build
together.**



Core Values



The Altrad Group's core values – Integrity is an essential condition for doing business. The Altrad Group established our Business Integrity & Ethics Code in line with the Altrad Group Values, aimed at promoting fair and transparent management practices. The Altrad Group Values and our Business Integrity & Ethics Code, guided the foundation of our comprehensive Compliance Program, and underpinned the formation of the core compliance policies.

Altrad Group Values:

RESPECT

We accept the responsibility as a group and as individuals to prevent situations that jeopardise the health and safety of everyone at our workplaces. We treat people with consideration, regardless of their position. We conduct our business in accordance with exemplary standards of transparency, integrity and honesty. We hold a deep sense of responsibility towards all of our stakeholders and the environment we work in.

SOLIDARITY

Solidarity is about teamwork and reliability. We collaborate and contribute to the different projects we undertake together by sharing ideas and opportunities, knowledge and resources. We support each other and stand up for each other. We always foster open and collaborative relationships and we put the common good before personal interests.

COURAGE

We are eager to reach out beyond new boundaries and we are willing to explore innovative ways of thinking and wording. What we do is therefore not easy: we are entrepreneurs and thus take risks and challenge ourselves permanently. Our objective is always to achieve the best outcome despite the difficulties.

HUMILITY

We are open to differing points of view and are convinced that we can learn from anyone, anywhere. We always act and lead in a manner that expresses a spirit of inclusion. We tend to learn from mistakes and successes in equal measure and, above all, we never underestimate our competition. For every project, we seek and provide honest feedback to reach our goals by continuous improvement.

CONVIVIALITY

Every day, we try to create a work environment that reflects the spirit of our teams, based upon commitment and open-mindedness. Together, we know how to share and to collaborate in a convivial spirit. We also celebrate success and combine functional excellence and cross-functional teamwork to produce exceptional ideas and results.

Business Integrity & Ethics Code



- Integrity is the cornerstone of Altrad's success. To embed this principle across our operations globally, we established the **Business Integrity & Ethics Code***—a framework that sets the standard for ethical behavior and responsible decision-making across the Group.
- Our **Business Integrity & Ethics Code** translates Altrad's values into a practical expectations for conduct. By following these principles, employees can ensure that we deliver on our social responsibilities and meet our commitments to stakeholders and the wider community.
- Our **Business Integrity & Ethics Code** is more than a policy—it is a statement of our values and determination to uphold them. By following its principles, every employee contributes to Altrad's reputation for integrity and helps secure a sustainable future.

* See the Ethics & Compliance link on the Altrad Australia website ([Altrad Australia | Trusted Partner in Industrial Services](#)) to download a copy of our **Business Integrity & Ethics Code**.

Core Compliance Policies



We are dedicated to acting with integrity by complying with all relevant laws, regulations and internal standards across every jurisdiction where we do business. Our focus is on key areas that represent critical responsibilities for conducting business ethically and without risk. The Altrad Group has a global suite of core compliance policies and procedures in place, which provide the ethical and legal foundation that guides our operations, ensuring integrity and long-term sustainability.

Anti-Bribery & Corruption

We have zero tolerance for all forms of bribery and corruption.

Altrad reaffirms its unwavering commitment to integrity and transparency in all business dealings, both essential in maintaining a clean, sustainable business. We operate under a strict zero-tolerance policy toward bribery and corruption, fully complying with international standards and regulations in all jurisdictions in which the Group operates, including *the Foreign Corruption Practice Act (FCPA)*, the *UK Bribery Act*, the *Sapin II Law* and the normative requirements of the ISO 37001 standard. This commitment extends to our global network of partners, who are contractually required to uphold the same ethical standards. By embedding these principles into every aspect of our operations, we safeguard trust, protect our reputation, and ensure sustainable growth for all stakeholders.

Bribery in any form is strictly prohibited. No employee or representative may offer, promise, give, or authorize anything of value – directly or indirectly – to gain an unfair business advantage, such as obtaining or retaining business. Likewise, accepting or agreeing to receive anything that could result in the improper performance of duties is forbidden.



Gifts & Hospitality

We do not give or accept any unlawful gifts or hospitality invites.

Gifts and hospitality can foster goodwill in business relationships. However, care must be taken when exchanging incidental business courtesies to avoid a conflict of interest or the perception of an undue advantage.

Business courtesies must be lawful, infrequent, reasonable and transparent.

Our employees are not to offer, give, or receive any gift or hospitality that could be perceived as an undue advantage, bribe, payoff, kickback or violation of any law or internal standards. Our employees may only offer or approve business courtesies that are legal, proper and in full compliance with our policies and guidelines.

Sponsorships & Donations

We only make sponsorships and donations that are legal and reflect our values.

Altrad supports legitimate charitable and community initiatives consistent with our values. All donations and sponsorships are vetted, approved and recorded; they must not be a conduit for improper payments. Any sponsorships or donations must be approved in accordance with any relevant policies.

Sponsorship and donations must never be carried out with the aim of obtaining an undue advantage or unduly influencing a decision.

Business Partners

We apply objective criteria and prioritise sustainable partnerships.



Altrad's business relationships are built on trust, integrity and ethical conduct. We work with clients, suppliers, and other partners/stakeholders globally, ensuring every relationship meets the highest of ethical standards.

To prevent bribery and corruption, and the perception thereof, all engagements follow rigorous internal procedures. Business partners must also comply with all applicable laws and regulations. Contractual agreements mandate obligations such as safeguarding confidential information and adhering to anti-corruption measures.

Partner evaluations are conducted through Altrad Group's online global Compliance Platform tool, GAN. These assessments apply varying levels of due diligence and mitigation measures based on the identified risk.

Conflict of Interest

We avoid conflicts of interest and act with transparency.

Altrad expects all employees and representatives to make decisions in the best interest of the company, free from any personal or external influence. A conflict of interest occurs when personal relationships, financial interests, or outside activities interfere – or appear to interfere – with professional judgement or responsibilities.

Altrad's employees must disclose any potential conflicts promptly and follow internal procedures for review and approval. We require transparency and accountability in all dealings, and we expect our business partners to uphold the same standards. Compliance with these principle helps protect our integrity and maintain trust with clients, partners and stakeholders.

Data Protection

We apply objective criteria and prioritise sustainable partnerships.

Where Altrad Group companies are in possession of personal and/or confidential data belonging to the Altrad Group, its clients, suppliers or other third parties, we are committed to ensuring this data is protected, stored and used in accordance with the data protection legislation in force.

-
- Detailed information on our Compliance Program and other related resources are available to Altrad employees on our GAN Compliance Platform.
 - See the Ethics & Compliance link on the Altrad Australia website ([Altrad Australia | Trusted Partner in Industrial Services](#)) to view our Business Integrity and Ethics Code, our Anti Bribery and Corruption Policy, our Whistleblowing Policy or to Make a Report.

Compliance Program



Our compliance program is essential for sustaining trust and long-term success. It ensures that Altrad's core policies are not only implemented but actively monitored, reinforcing ethical conduct across all operations.

Compliance Program

At Altrad, compliance is more than a legal requirement—it reflects our commitment to integrity and responsible business. Our Compliance Program embeds ethical principles into daily activities, helping employees act with confidence and transparency. Through clear policies, ongoing education, and proactive monitoring, we create a culture where doing the right thing is part of who we are.

Compliance, financial and operational controls are implemented at both first and second levels. In addition, external and internal audits are carried out on the Group's Compliance Program and its application across all subsidiaries.

ISO 37001 Certification

Altrad Australia is proudly certified to ISO 37001:2016, the international standard for Anti-Bribery Management Systems. This certification demonstrates the organisation's commitment to maintaining robust governance controls, preventing bribery and corruption, and upholding the highest ethical standards across all operations. Achieving and maintaining ISO 37001 certification reflects Altrad Australia's dedication to continuous improvement, strong leadership oversight, and a culture of integrity embedded throughout the business.

Organisational Structure

The Altrad Group adopts a zero-tolerance policy regarding corruption. The Altrad Group's anti-corruption management system is based on compliance with the legal requirements of the countries in which the Group operates, including the *Foreign Corruption Practice Act (FCPA)*, the *UK Bribery Act*, the *Sapin II Law* and the normative requirements of the ISO 37001 standard. The parent company of the Altrad Group is a French company - AIA - therefore, and pursuant to Article 17 of the *Sapin II Law*, all subsidiaries must comply with French legislation.



Organisational Structure

The purpose of this framework is to provide the rules, the spirit, the main principles and to identify the roles of individuals in the Compliance program. It is the founding framework reflecting Altrad Group management's desire to be proactively involved in the fight against corruption by means of an effective anti-corruption management system.

The Altrad Group introduced the Business Integrity & Ethics Framework. Each company must comply with this Framework, whilst also complying with applicable local laws.

Altrad Group's compliance organisation consists of a centralized compliance department composed of a CCO, Head of Compliance and Regional Compliance Officers. The Group also has an Ethics Committee that meets quarterly to oversee and ensure the effective implementation of the global compliance action plan. The Group's key Compliance roles are detailed below.





Organisational Structure

At the local level, compliance officers are positioned globally, each serving as a delegate for their respective business unit within the Group. Every business unit also has a Local Ethics Committee that convenes quarterly, with the country's Group Compliance Officer participating in these meetings. Each unit is accountable for completing risk maps for compliance areas (corruption, data privacy, antitrust) and sanctions, and developing an annual compliance action plan, with the achievement of objectives directly linked to local management performance bonuses.

A key element of the compliance structure is the reporting line between the Local Compliance Officers (LCOs) to Regional Compliance Officers, strengthening the connection between local business units and Group Compliance oversight while supporting coordinated program delivery.

For compliance purposes, Altrad Australia's LCO reports directly to the CEO and to the Group Regional Compliance Officer, reflecting strong executive oversight and the organization's commitment to compliance. Business unit key compliance roles are defined below:

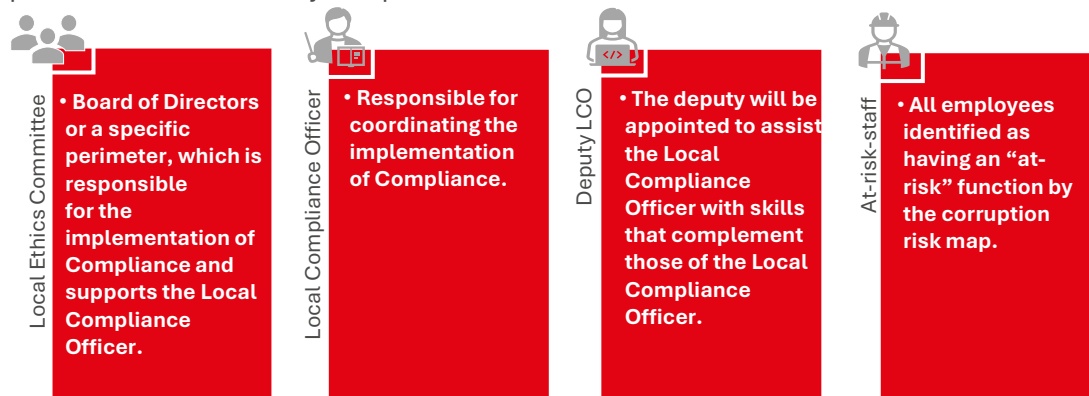

Organisational Structure

The hierarchy can be represented as follows:

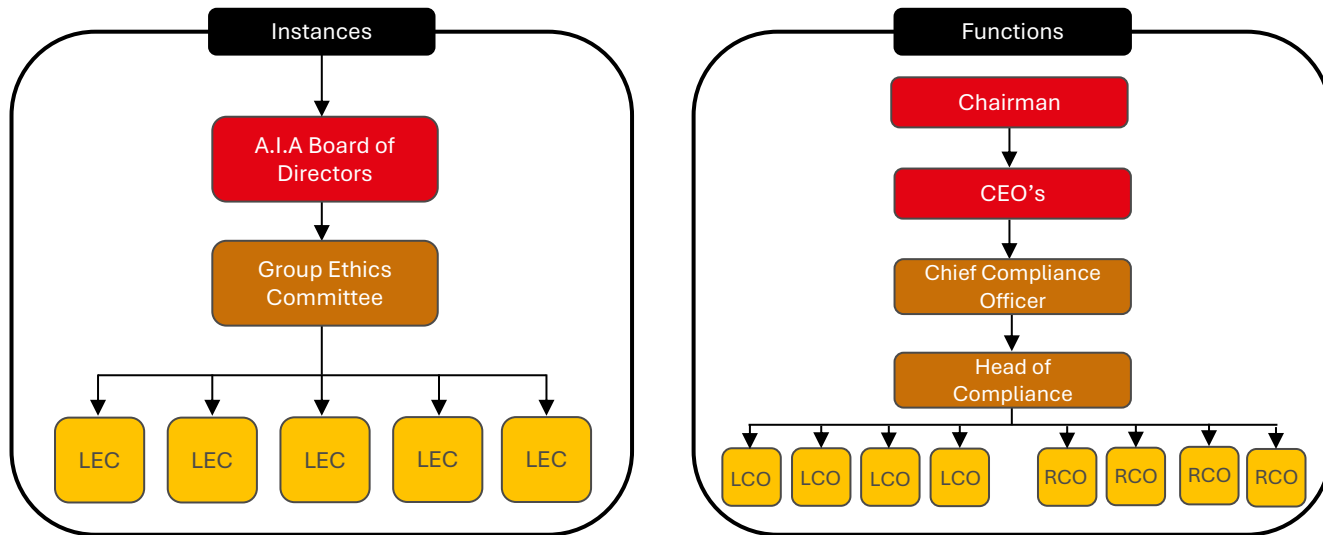

Controlled Documents

Aligned with Altrad Group values, our Business Integrity & Ethics Code, and core compliance policies, we have developed practical internal guidelines, procedures, and processes to ensure the proper conduct of daily business activities. These resources support employees in making professional, fair, and lawful decisions. All documents are accessible via the Altrad intranet and reinforced through regular online and in-person training sessions. External stakeholders can access and download our Business Integrity and Ethics Code, our Anti Bribery and Corruption Policy, and our Whistleblowing Policy through the Ethics & Compliance link on the Altrad Australia website ([Altrad Australia | Trusted Partner in Industrial Services](#)).



Communication & Training

The Altrad Group delivers global compliance training to build program management skills, ensure legal awareness, and to promote integrity and an ethical culture among its employees and partners.

Altrad employees globally receive ongoing compliance training—via eLearning and in-person—covering key topics such as anti-bribery and corruption, third party due diligence, whistleblowing, and data protection, tailored for general staff or to those staff actively working in compliance program roles—finance, procurement, commercial—to enhance awareness of compliance risks and provide essential knowledge of applicable regulations. Altrad Australia delivers national in-person training covering all at-risk personnel across office, site, and contractor groups.

The Group strongly believes that innovative communication methods are key to fostering a culture of compliance. Communications are reinforced through the GAN Compliance platform, requiring core compliance policy acknowledgement, and supported locally through posters, videos, emails, or live toolbox talks. To further encourage engagement, Altrad has introduced annual compliance awards that recognise outstanding initiatives in compliance-related management, leadership, and innovation.

Improvement & Monitoring

The Altrad Group has established a compliance monitoring system that assigns Group Compliance responsibility for setting up a monitoring plan for deployment across all Companies. This plan is adapted according to the level of risk determined by subsidiary, related history, and the assessment carried out by managers on the Group Ethics Committee. The Head of Compliance reports to the Group Ethics Committee at least once a year on predefined performance indicators such as the number of Ethics Committees held, the number of alerts raised and the training rate.

Although the monitoring system is established and implemented at Group level, it is governed locally through quarterly Local Ethics Committee meetings. During these meetings, key performance indicators (KPIs) are shared and reviewed.



Misconduct Consequences

Any breach of the Bribery Integrity & Ethics Code and the applicable policies may result in disciplinary action, breach of contract for misconduct, up to and including dismissal and/or legal proceedings, depending on the seriousness of the offence.

Altrad Australia encourages the use of the Altrad Group Whistleblowing resources to report any known, suspected, or potential misconduct

Compliance Platform

The Altrad Group maintain an online global Compliance Platform, GAN Compliance, the purpose of which is to drive the Group culture in doing not only what the law requires but also acting ethically and in accordance with our Business Integrity & Ethics Codes and Group policies. Each and every Altrad employee has a vital role to play in maintaining the Group's ethical standards.

GAN Compliance supports employees worldwide to complete compliance related activities. GAN Compliance provides comprehensive information about the Compliance Program, including applicable laws and regulations, internal policies and documents, control tools for key topics such as gifts and hospitality or conflicts of interest, our third-party due diligence application, and recent compliance issues. GAN Compliance also serves as a mechanism through which our employees undertake targeted training sessions.

Compliance Resources

The Altrad Group maintains a centralised Compliance SharePoint platform that houses all Group-level compliance resources, including global policies, procedures, training materials, and guidance documents, with access appropriately restricted to authorised global compliance personnel.

Altrad Australia operates its own confidential “My Compliance” SharePoint site, with access limited to local compliance personnel under Altrad Group Compliance oversight. This platform hosts Australian legislation reviews, locally adapted training materials, business-unit-specific guidance documents, and compliance resources tailored to Australia’s regulatory environment. By providing a secure and structured repository for critical compliance information, the SharePoint site enhances local compliance capability and supports consistent alignment with Group-wide governance expectations.

Whistleblowing

Speaking up is essential in safeguarding Altrad’s reputation and ethical culture. If you suspect a breach of law or company policy, you are encouraged to report it so we can address the issue promptly. The Altrad Group Whistleblowing system is available to internal and external stakeholders, accessible via GAN Compliance directly, through scanning a QR code, through our website* or our dedicated Whistleblowing Hotline telephone number, allowing employees and stakeholders to report concerns (breaches of the Bribery Integrity & Ethics Code or any other relevant concerns) on a confidential basis.

The Whistleblowing system can be used to report in good faith any suspicion of illegal, unethical or inappropriate behavior. We handle all reports with discretion and will never allow retaliation against anyone who raises a concern in good faith.



* See the Ethics & Compliance link on the Altrad Australia website ([Altrad Australia](#)) to download our Whistleblowing Policy or Make a Report (or scan the QR Code)

Detailed information on our Compliance Program and other related resources are available to Altrad employees on our GAN Compliance Platform.



ALTRAD AUSTRALIA

+61892359500

au.info@altrad.com

www.altrad.com.au